

The UPA-100 Power Alert **reduces the risk of electrical arc flash** by pre-verifying the electrical isolation from outside of a control panel. Hardwired to the circuit breaker or main disconnect, the UPA flashes whenever voltage is present. Engineered with **redundant circuitry**, the Power Alert is powered by the same voltage that it indicates.

OPERATION

The eight detector UPA-100 visually alerts to the presence of dangerous AC or DC (Stored Energy) potentials occurring between any combination of the four monitored input lines (L1, L2, L3, GND). Two LED indicators are assigned to each input line and are designated "+" and "-". For each input line carrying an AC potential (bi-polar), both the "+" and "-" LEDs will be active. A DC or Stored Energy potential will illuminate the "+" LED for the positive line and the "-" LED for the negative line.

OSHA 1910.147 THE CONTROL OF HAZARDOUS ENERGY (LOCKOUT/TAGOUT)

Following the application of lockout or tagout devices to energy isolating devices, all potentially hazardous stored or residual energy shall be relieved, disconnected, restrained, and otherwise rendered safe. (d)(5)(ii)

If there is a possibility of reaccumulation of stored energy to a hazardous level, verification of isolation shall be continued until the servicing or maintenance is completed, or until the possibility of such accumulation no longer exists. (d)(6)

"Verification of Isolation." Prior to starting work on machines or equipment that have been locked out or tagged out, the authorized employee shall verify that isolation and de-energization of the machine or equipment have been accomplished.



NEMA 4X

Universal Power Alert

SPECIFICATIONS

OPERATIONAL RANGE	AC Single or 3-Phase	40 to 750 VAC, 50/60/400 Hz, (LINE-TO-LINE or LINE-TO-GND)
	DC or Stored Energy	30 to 1000 VDC, (LINE-TO-LINE or LINE-TO-GND)
MAXIMUM RATED VOLTAGE	750 VAC/1000 VDC (LINE-TO-LINE or LINE-TO-GND)	
DETECTION THRESHOLDS	29 VAC 3-Phase, 40 VAC SINGLE-Phase, 27 VDC (TYP Cutoff)	
POWER CONSUMPTION	1.2 Watts @ 750 VAC (Approximately)	
TEMPERATURE RATING	Operate	-4° to 131°F (-20° to +55°C)
	Storage	-40° to 185°F (-40° to +85°C)
ENCLOSURE	NEMA 4X 105°C PVC, Totally Encapsulated for Environment Protection	
TERMINATIONS	(4) 8ft, 18 AWG 1000V, UL-1452	
WEIGHT	9 oz.	

- Detects Single or 3-Phase AC & DC Voltage or Stored Energy
- Redundant Circuitry
- Verification of Zero Energy in a Panel
- Fits 1-1/4" Conduit Knock-Out

ORDERING INFORMATION

MODEL NUMBER	DESCRIPTION
UPA-100	Universal Power Alert

DIMENSIONS (INCHES)

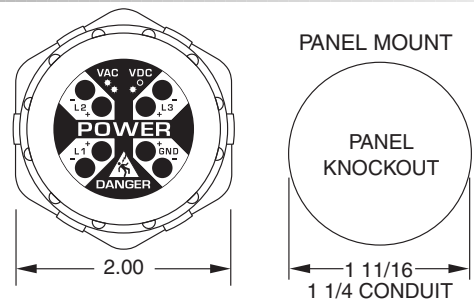

INDICATOR FLASH RATES (L1, L2, L3, GND)

3- Phase Line-To-Line (VAC)	<29	30	120	240	480	600	750
Flashes/Sec (Typical)	0	1.3	4.2	5.8	7.3	8.0	8.8
DC or Stored Energy (VDC)	<27	30	48	110	300	600	1000
Flashes/Sec (Typical)	0	1.6	2.5	4.5	6.9	8.8	9.1

GND DETECTOR THRESHOLDS (LEAKAGE ANY PHASE-TO-GROUND)

3- Phase Line-To-Line (VAC)	30	120	240	480	750
L1, L2, or L3 To Ground Continuity (OHMS)	2M	2M	3M	5M	7M
Detector Included Fault Current (µA)	7	26	38	60	67

DETECTOR INCLUDED FAULT CURRENT (PHASE-TO-GROUND SHORT)

3- Phase Line-To-Line (VAC)	30	120	240	480	750
0 OHM Phase-To-Ground Current (µA)	28	108	219	455	730

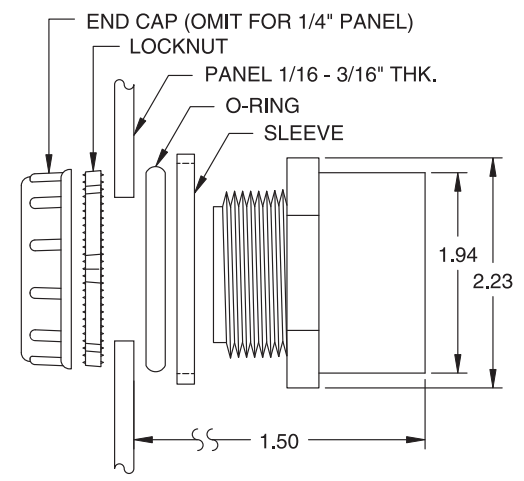

INSTALLATION: INSIDE PANEL SURFACE MUST BE UNIFORM. TIGHTEN LOCKNUT UNTIL SLEEVE BOTTOMS-OUT.

Power Alerts // UPA-100 Series